

MA5767 ALUMINIUM BOTTOM RAIL

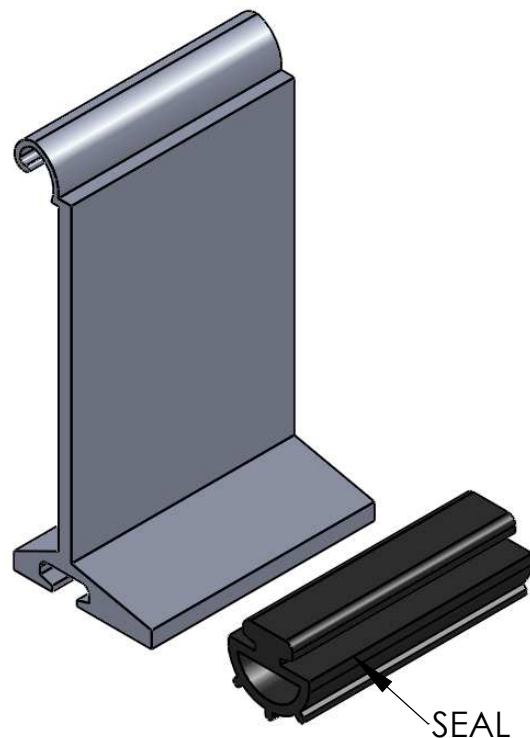

CLEARMASTER BOTTOM RAIL

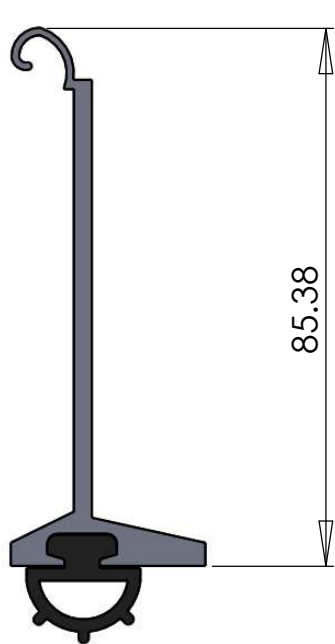
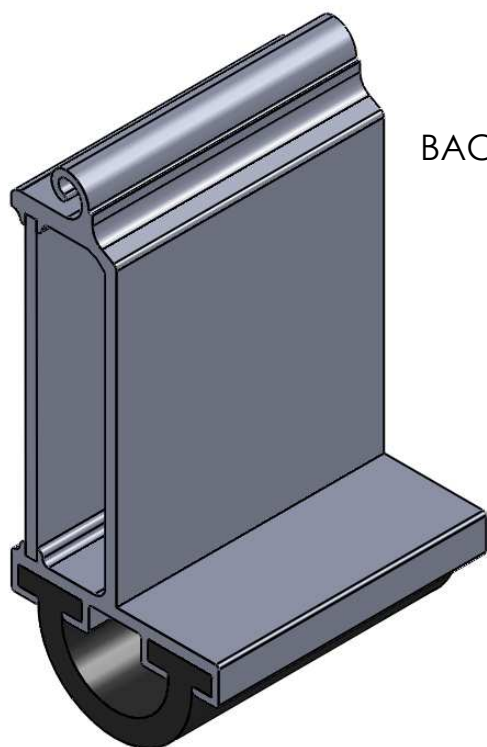

BACK COVER

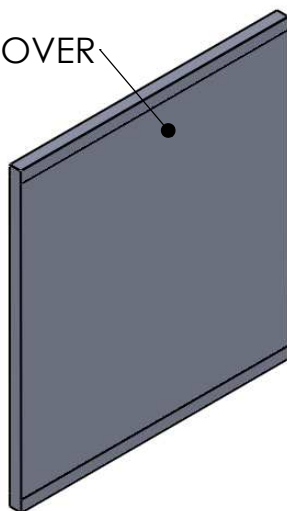

BOTTOM RAIL SEAL

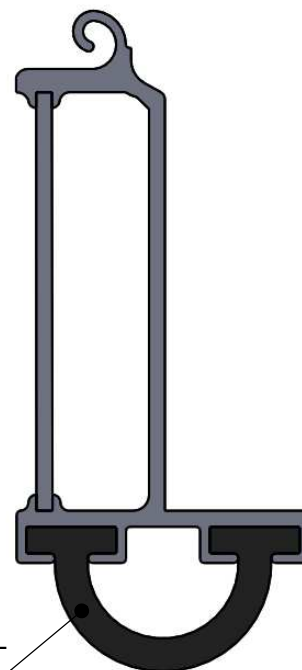

CLEARMASTER BOTTOM RAILS

SCALE
NTS

AUSTRAL MONSOON INDUSTRIES P/L
50 Orchardleigh Street Yennora, nsw, 2161 Australia
P.O Box 294 Fairfield, NSW, 2165 Australia

DRAWN
H.P.LY

Phone: +612 9892 3188 Fax: +612 9892 2167

DATE
20/09/10

DWG No: AMI-AL0024B

CONFIDENTIAL NOTE: This drawing and its designs, specifications and engineering information disclosed hereon are the property of AUSTRAL MONSOON INDUSTRIES P/L and are not to be disseminated or reproduced without express written consent. The drawing is loaned in confidence and then only for consideration of the matter hereon. In accepting loan of this drawing, the recipient agrees to keep it and the matter disclosed hereon in confidence and not to use nor permit their use in any way detrimental to AUSTRAL MONSOON INDUSTRIES P/L.